

Georg Fischer Waga N.V.

# MULTI/JOINT® 3000 Plus DN625-DN1025



INCH  
25" - 41"

PAGE

18



# +GF+

User Manual	EN
Montageanleitung	D
Montagehandleiding	NL
Manuel d'instruction	F
Brukermanual	NO
Användarmanual	SE
Montagevejledning	DK
Käyttömanuaali	FIN
Manual de instalacion	ES
Manual de instalação	PT
Manuale d'uso	IT
Manualul utilizatorului	RO
Návod k montáži	CZ
Εγχειρίδιο χρήσης	GR
Szerelési utasítás	HU
Руководство по установке	RUS
Instrukcja Obsługi	PL

Instructions in English, Dutch and German prevail.  
Other languages informative only!

Georg Fischer Waga N.V.  
Lange Veenteweg 19, 8161 PA, Netherlands  
T +31 (0) 578 678 378  
waga.ps@georgfischer.com  
www.waga.nl / www.multijoint.nl

© Georg Fischer Waga N.V.  
2023, produced in the Netherlands

### **Közegészségügyi megjegyzés az 5/2023. (I.12.) Korm. rendelet szerint**

Nyilvántartásba vétel/engedély száma: 28142-7/2020/KTEF

Alkalmazási terület: ivóvíz-ellátás

Maximális alkalmazási hőmérséklet: max 30 °C

***A termék megfelel az ivóvíz minőségi követelményeiről  
és az ellenőrzés rendjéről szóló 5/2023. (I.12.) Korm.  
rendelet előírásainak.***

### **OUR WEBSITES**

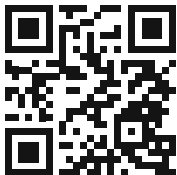

## CHECK TABLE IF CHOSEN FITTING MATCHES PIPE OD.

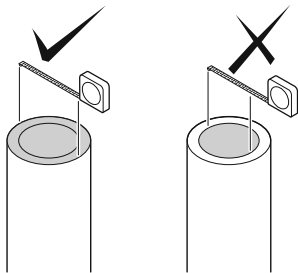

D

Die Rohraussendurchmesser überprüfen und mit der Tabelle vergleichen.

NL

Kies de juiste koppeling m.b.v. de tabel.

F

Vérifiez sur le tableau si le raccord couvre bien le diamètre extérieur du tube.

NO

Sjekk med tabell at koblingen stemmer overens med utvendig diameter rør.

SE

Kontrollera om vald rördel stämmer mot rörets ytterdiameter.

DK

Kontroller med tabellen om den valgte kobling passer til rørdiameteren.

FIN

Tarkista taulukosta jos valitut asennukset sopivat putkelle QD.

PT

Ver na tabela se os acessórios estão de acordo com o diâmetro exterior dos tubos.

ES

Ver tabla anexa para unir distintos diámetros exteriores.

IT

Controllare sulla tabella se il giunto è idoneo al d.e. del tubo.

GR

Με βάση το πίνακα μεγεθών, επιβεβαιώστε ότι ο σύνδεσμος είναι κατάλληλος για τη συγκεκριμένη διάμετρο αγωγού στον οποίο πρόκειται να τοποθετηθεί.

CZ

V tabulce zkontrolovat použitelnost tvarovky v daném rozsahu průměrů.

HU

Ellenőrizze, hogy a kiválasztott idom megfelel-e a cső külső átmérőjéhez.

RO

Se verifica in tabel daca fittingul ales corespunde Dext al tevii.

PL

Sprawdź w tabeli czy łącznik pasuje do zewnętrznej średnicy rury.

RUS

Проверить по таблице совместимость фитинга с трубой.

DN	Range (mm)
DN625	630 – 662
DN675	665 – 697
DN700	709 – 741
DN750	745 – 777
DN800	799 – 831

DN	Range (mm)
DN825	837 – 869
DN900	899 – 931
DN925	939 – 971
DN1000	994 – 1026
DN1025	1042 – 1074

2

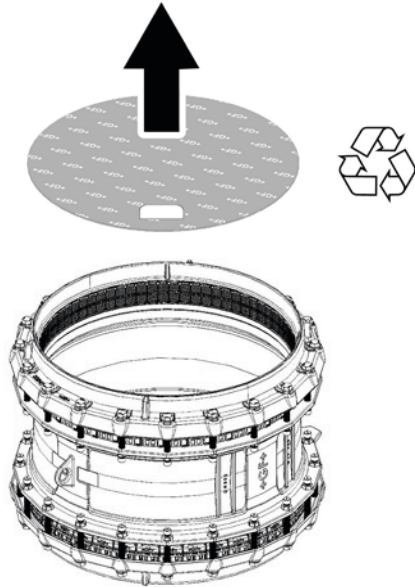
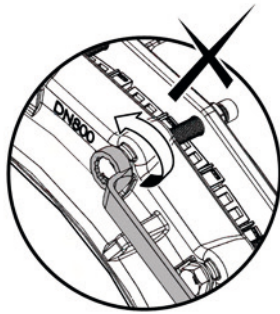

## CHECK IF "FIKSERS" (METAL GRIPPERS) POSITION IS CORRECT.

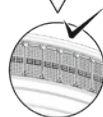
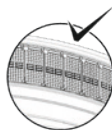

D Sicherstellen, dass alle Fikser richtig positioniert sind.

NL Controleer de juiste positie van de "Fiksers".

F Assurez-vous que les "Fiksers" (les mors métalliques) sont correctement positionnés.

NO Kontrollert at "Fikserne" er i riktig posisjon.

SE Kontrollera om "Fiksers" position är korrekt.

DK Kontrollert om "Fikernes" placering er korrekt.

FIN Tarkista "Fikseri", että asento on oikein.

PT Ver se a posição dos "Fiksers" é correto.

ES Revise si los "Fiksers" se encuentran en la posición correcta.

IT Controllare gli inserti antisfilo "Fiksers" sono OK.

GR Ελέγξτε αν τα εξαρτήματα αγκύρωσης που διαθέτει ο σύνδεσμος "Fiksers" έχουν αγκυρώσει σωστά πάνω στον αγωγό.

CZ Zkontrolovat správnou polohu fixerů.

HU Ellenőrizze, hogy a "Fikser"-ek megfelelő helyzetben vannak-e.

RO Se verifica dacă poziția elementelor de fixare "Fiksers" este corectă.

PL Sprawdzić poprawność ułożenia blaszek.

RUS Убедиться в правильности установки "Fiksers" (металлических фиксаторов).

## 4

## REMOVE ALL RUST, DIRT, BURRS, AND DAMAGES FROM THE PIPE. INSTALL ON MEDIUM CARRYING PIPE MATERIAL ONLY.

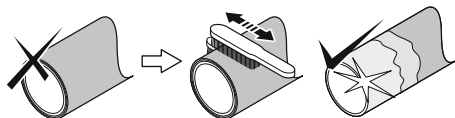
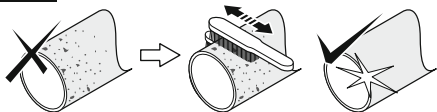

D

Entfernen sie auf dem rohr den gesamten rost-, schmutz-, grate- und beschädigungen. Nur auf der rohroberfläche des medium transportierenden rohr es installieren. (PE) schutzmantel sind zu entfernen.

NL

Verwijder alle roest, vuil, bramen en beschadigingen. Monteer alleen op de mediumvoerende buis.

F

Éliminez la rouille, la saleté, les bourrelets de soudures et les défauts de surface du tube. Assemblez seulement sur le matériau principal du tube.

ES

Retirar toda la suciedad, polvo y daños de la tubería. Instalar solo en la tubería que transporte el agua.

NO

Fjern all rust, skitt, riper og skader fra røret. Installer kun på selve medierørets material.

SE

Avlägsna all rost och smuts samt avgrada och ta bort ytdefekter på røret. Montera endast på mediabärande rörmaterial.

DK

Fjern al rust, snavs, spåner, belægninger og beskadigelser fra røret. Montér kun på selve det medie bærende rør.

FIN

Poista aina putkenpinnalta ruoste, irtoaines, vahingoittunut materiaali, lovet ja putkipinnoitteet. Asennus ainoastaan hyväksytyille putkimateriaaleille.

PT

Remove toda a ferrugem, sujeira e a parte danificada da tubulação. Instalar somente em tubulações feitas para transporte de fluidos.

HU

Távolítson el minden rozsdát, szennyeződést, sorját és sérülést a csőről. Csak közvetlenül a közegszállító csőanyagra helyezze fel az idomot.

IT

Rimuovere ruggine, sporco, bave e intagli dal tubo. Rimuovere eventuali rivestimenti dal tubo prima di installare il raccordo.

GR

Αφαιρέστε όλες τις οξειδώσεις, τις ακαθαρσίες, τις παραμορφώσεις και τις αλλοιώσεις υλικού από την επιφάνεια του αγωγού. Αγκυρώστε αποκλειστικά επί επιφάνειας του αγωγού μεταφοράς του ρευστού.

CZ

Odstranit všechny nečistoty, rez a otřepy z povrchu trubky. Montovat pouze na trubky určené pro transport médií.

RO

Înlăturati rugina, mizeria, bavurile și defectele de pe teava. Instalați doar pe materialul conductei care este în contact cu fluidul transportat.

PL

Usuń z rury rdzę, brud, zadziory i inne uszkodzenia. Instalować tylko na materiale rury, który ma kontakt z medium.

RUS

Удалить любые загрязнения, ржавчину, задиры и повреждения с поверхности трубы. Устанавливать только на основной материал несущей трубы.

## 5

## CHECK TABLE FOR MINIMUM INSERTION DEPTH (X).

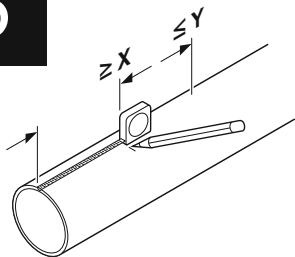

\* For maximum joint gap information, see our table:



DN	X Min. insertion depth (mm)	Y Max. insertion depth (mm)
DN625	210	320
DN675		
DN700		
DN750		
DN800		
DN825		
DN900	355	
DN925		
DN1000		
DN1025		

**D** Aus der Tabelle Einstecktiefe min. und max. entnehmen und auf dem Rohr markieren.

**NL** Zie de tabel voor de minimale insteekdiepte (X).

**F** Vérifiez sur le tableau la profondeur d'insertion (X) correcte du tube.

**NO** Sjekk med tabell for korrekt innstikksdybde (X).

**SE** Kontrollera i tabellen korrekt insticksdjup (X).

**DK** Kontroller med tabellen for korrekt indstikksdybde (X).

**FIN** Tarkista taulukosta oikea asennus syvyys (X).

**PT** Ver na tabela a profundidade (X) de inserção do tubo no acessório.

**ES** Ver tabla para la profundidad de inserción mínima (X).

**IT** Controllare sulla tabella la profondità di inserimento (X).

**GR** Συμβουλευτείτε τον πίνακα για την υπόδειξη του κατάλληλου βάθους εισαγωγής (X) του συνδέσμου στον αγωγό.

**CZ** Zkontrolovat v tabulce správnou hloubku zasunutí (X).

**HU** Ellenőrizze a táblázatot a megfelelő betolási mélység érdekében (X).

**RO** Se verifica in tabel adancimea corecta de inserare (X).

**PL** Korzystając z tabeli określ głębokość nasunięcia łącznika (X).

**RUS** Проверить по таблице значение глубины ввода трубы (X).

6

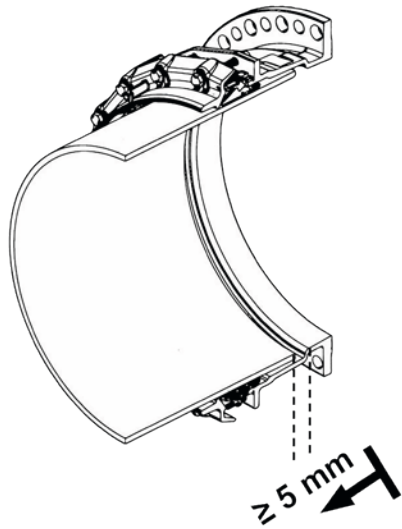
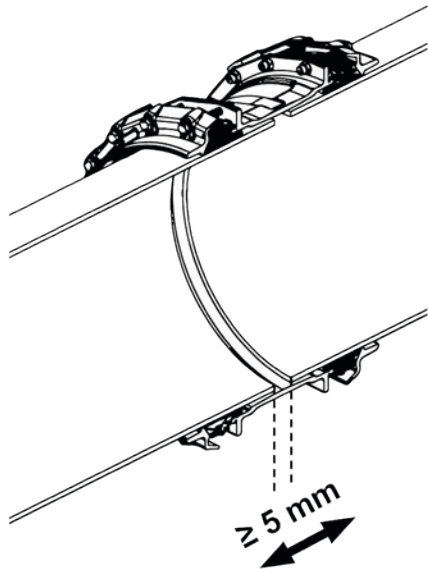



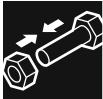

# LIFTING PROCEDURES

**EN:**

When manoeuvring the product out of the packaging to the pipe surface, please ensure that the proper lifting procedures are followed. Ensure that local safety and lifting procedures are adopted. All lifting should be done by qualified personnel, with approved equipment.

**NL:**

Zorg ervoor dat bij het manoeuvreren van het product vanuit de verpakking naar het buisoppervlak, de juiste hijsprocedures in acht worden genomen. U dient de lokale veiligheids- en hijsvoorschriften op te volgen. Het hijsen van producten dient te gebeuren met gekeurde hijsmiddelen en door gekwalificeerd personeel.

**DE:**

Bitte stellen Sie eine ordnungsgemäße manuelle Handhabung sicher, wenn das Produkt aus seiner Verpackung entnommen, transportiert und am Rohr angebracht wird. Ist der Einsatz mechanischer Hebezeuge erforderlich, so muss gewährleistet werden, dass sichere Arbeitsverfahren angewendet werden, geprüfte und anerkannte Hebezeuge verwendet werden und von qualifiziertem Personal durchgeführt werden.

# 7

## INSERTS FOR PLASTIC PIPES. NOMINAL ANGULARITY.\*

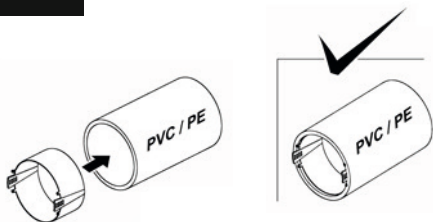

(Use insert stiffener wedge MJ DN625 - DN1000  
approved by Georg Fischer Waga N.V.)

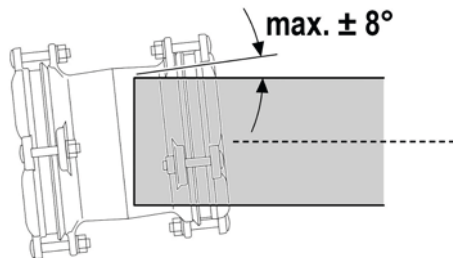
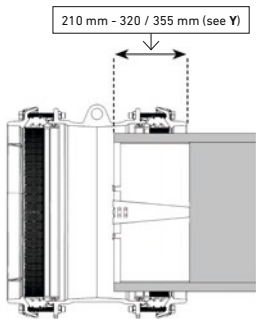

\* Based on the middle of the range.

# SLIDE THE MULTI/JOINT® 3000 PLUS ONTO PIPE END AND REMOVE TRANSPORT CLIP!

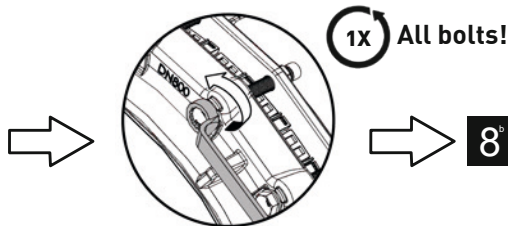
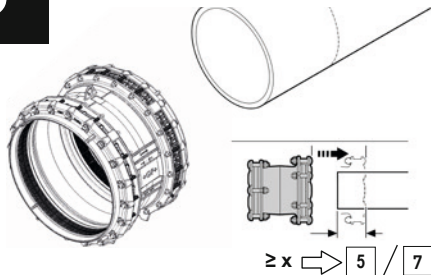

**D** Den MULTI/JOINT® 3000 Plus auf das Rohrende schieben und den Transportclip entfernen! Der Anpressring muss im Bereich der minimalen und der maximalen Einstecktiefe liegen.

**NL** Schuif de MULTI/JOINT® 3000 Plus op het buiseinde en verwijder de transportclips!

**F** Faites glisser le MULTI/JOINT® 3000 Plus sur l'extrémité du tuyau et retirez le clip de transport!

**NO** Skli MULTI/JOINT® 3000 Plus muffe innpå rørende og deretter fjern transportpinnen.

**SE** Skjut MULTI/JOINT® 3000 Plus kopplingen på röret och ta bort transportsäkringarna (clip)!

**DK** Skub MULTI/JOINT® 3000 Plus på røret og fjern transportbeslaget!

**FIN** Liu'uta MULTI/JOINT® 3000 Plus putken päälle ja poista kuljetus klipsi!

**PT** Deslize o MULTI/JOINT® 3000 Plus na extremidade do tubo e remover o clipe de transporte!

**ES** Deslice el MULTI/JOINT® 3000 Plus sobre el extremo del tubo y retire el clip de transporte!

**IT** Inserire MULTI/JOINT® 3000 Plus sul tubo e successivamente rimuovere i fermi per il trasporto!

**GR** Εισάγετε το multi/joint® 3000 plus στο ακρο του αγωγού και αφαιρέστε το κομπωμά μεταφοράς!

**CZ** Nasunout tvarovku MULTI/JOINT® 3000 Plus na konec trubky a teprve potom odstranit oranžové vymešovací díly!

**HU** Csúsztassa a MULTI/JOINT® 3000 Plus kötődíomot a csővégre, és távolítsa el a szállítási rögzítőelemet!

**RO** Introduceți piesa MULTI/JOINT® 3000 Plus pe capatul conductei și înlaturați siguranta pentru transport!

**PL** Nasuń łącznik MULTI/JOINT® 3000 Plus na rurę a następnie zdejmij zabezpieczenie transportowe!

**RUS** Установите MULTI/JOINT® 3000 Plus на конец трубы и удалите транспортировочный хомут!

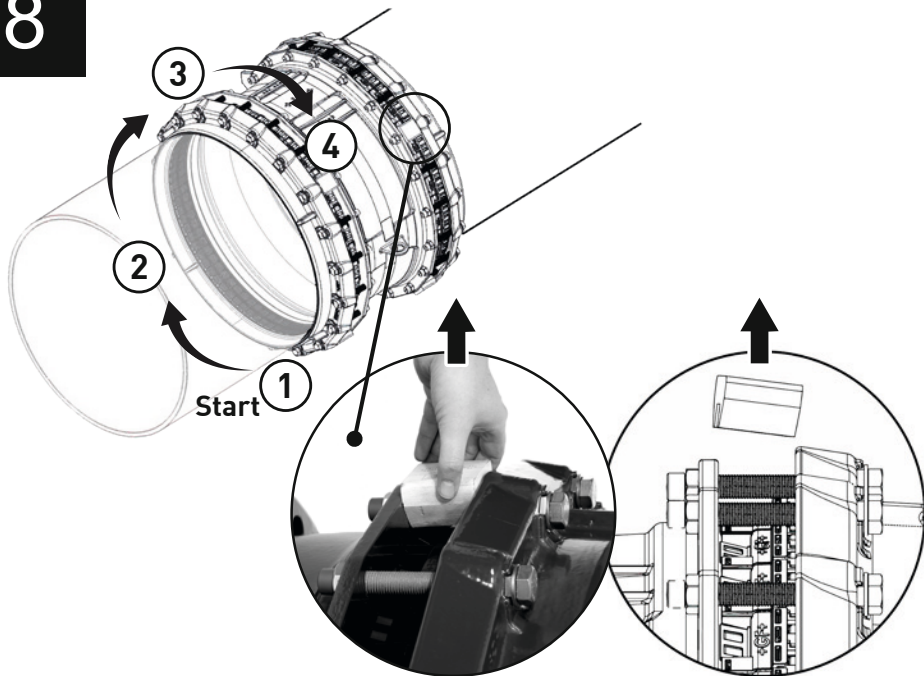
**8<sup>b</sup>****SLIDE THE MULTI/JOINT® 3000 PLUS ONTO PIPE END AND REMOVE TRANSPORT CLIP!**

## TIGHTEN THE BOLTS WITH THE CORRECT TORQUE.

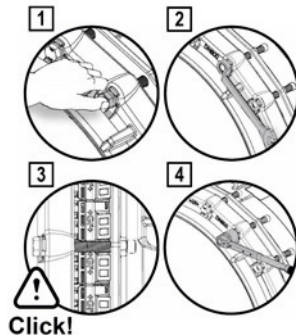
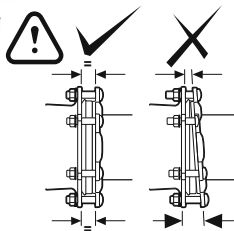
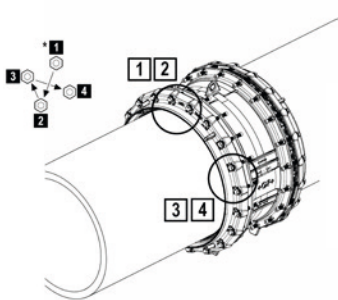

**D** Der Tabelle das richtige Schraubendrehmoment entnehmen und Schrauben fachgerecht anziehen. Die Verwendung eines Drehmomentschlüssels ist zwingend erforderlich. Beim Anziehen der Schrauben ist die Einstecktiefe zu kontrollieren.

**NL** Zie de tabel voor het juiste aandraaimoment.

**F** Vérifiez dans les tableaux le couple de serrage à respecter.

**NO** Mutrene strammes i kryss, da man skal holde samme avstand mellom koblingshus og trykkflens(gland). Etterstram med en momentnøkkel ihht. Momenttabell.

**SE** Kontrollera i tabell korrekt åtdragningsmoment.

**DK** Det rigtige tilspændingsmoment findes i tabellen.

**FIN** Tarkista taulukosta oikea vääntömomentti.

**PT** Ver na tabela a força de aperto.

**ES** Ver tabla para el par de apriete.

**IT** Controllare la tabella per il serraggio.

**GR** Συμβουλευτείτε τον πίνακα για την επιλογή της κατάλληλης στρεπτικής ροπής που θα πρέπει να εφαρμοστεί στον σύνδεσμο, κατά την διαδικασία της σύσφιξης του στον αγωγό.

**CZ** Zkontrolovat v tabulce správný utahovací moment.

**HU** Ellenőrizze a táblázatot a megfelelő nyomaték érdekében.

**RO** Se verifica in tabel valoarea momentului de stangere.

**PL** Odczytaj z tabeli odpowiedni moment dokręcania śrub.

**RUS** Проверить по таблице соответствующий момент затяжки болтов.

9<sup>b</sup>**CHECK TABLE FOR INSTALLATION TORQUE AND PRESSURE RATING\*\*.****RESTRAINT**

MULTI/JOINT®  
3000 Plus  
with Fikser



(S)St, DCI, GCI, AC\*, GRP\*, PVC, PE, PEX  
Consult GF for CU, PP, ABS

DN	Torque (Nm)		PFA water (bar)
	Metal	Non metal	
DN625	200	140	10
DN675			
DN700			
DN750			
DN800			
DN825			
DN900			
DN925			
DN1000			
DN1025			

**NON RESTRAINT**

MULTI/JOINT®  
3000 Plus  
without Fikser

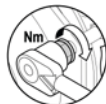

(S)St, DCI, GCI, AC, GRP, PVC, PE, PEX  
Consult GF for CU, PP, ABS

DN	Torque (Nm)	PFA water (bar)
DN625	140	16
DN675		
DN700		
DN750		
DN800		
DN825		
DN900		
DN925		
DN1000		
DN1025		

\* NO guarantee as quality varies!

\*\* All fittings PN16 rated, see restraint table for pull out restraint forces

# 10

≤ 0 °C ONLY ON PE PIPE, APPLY TORQUE (PRESCRIBED UNDER 10) ONE MORE TIME AFTER 30 MINUTES.

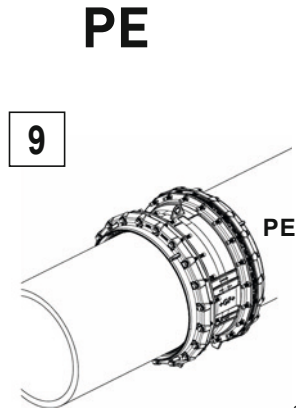

D

Nur für Einsatz auf PE Röhren bei Temperaturen ≤ 0 °C, das unter 9 ermittelte Schraubendrehmoment nach 30 Minuten noch einmal aufbringen.

NL

Alleen bij montage op PE bij temperaturen onder 0 °C, het (onder 9) voorgeschreven draaimoment na 30 minuten nog eenmaal aanbrengen.

F

Répetez l'étape 9 après 30 minutes seulement sur des tubes en PE en temps glacial.



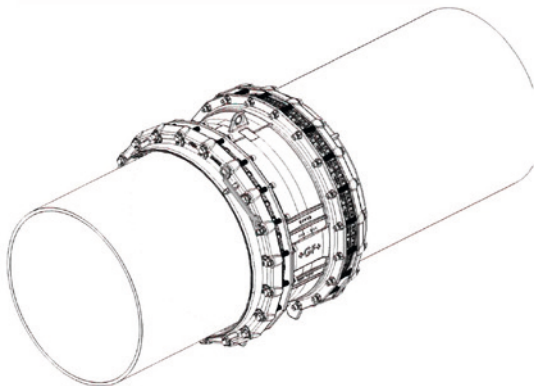
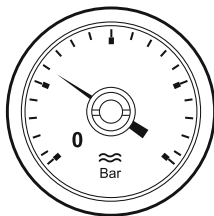

$$P_{\max} \leq 1,5 \times PFA$$

D Dichtheitsprüfung durchführen.

NL Voer een druktest uit.

F Procédez à un essai de pression.

NO Utfør trykktest på hele installasjonen, med minimum det aktuelle driftstrykk for anlegget dekkes til. Trykktestingen må ikke overstige 1,5 x PFA (max arbeidstrykk) i henhold til tabellen.

SE Utför tryckprovning.

DK Gennemfør en trykprøvning.

FIN Aseta painetesti.

PT Efetuar teste de pressão.

ES Realizar un test de presión.

IT Fare test in pressione.

GR Για τον έλεγχο της στεγανότητας της σύνδεσης πραγματοποιείτε δοκιμή υπό πίεση στον αγωγό για τυχόν διαρροές.

CZ Provést tlakovou zkoušku.

HU Hajtson végre nyomáspróbát.

RO Se realizeaza un test de presiune.

PL Przeprowadź próbę ciśnieniową.

RUS Провести опрессовку.



# 12

## IF PRESSURE TEST FAILS: REINSTALL FITTING. TEST OK → INSTALLATION FINISHED.

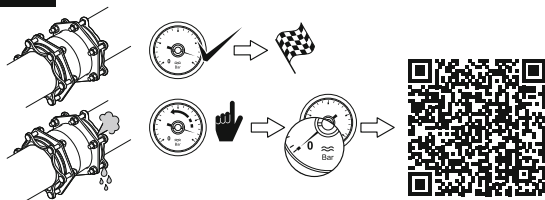

Disassembly  
& Reuse

D

Falls die Dichtheitsprüfung eine Undichtheit aufzeigt, den Montagevorgang wiederholen - nach wiederholter, erfolgreicher Dichtheitsprüfung ist die Montage abgeschlossen.

NL

Druktest negatief → opnieuw installeren. Test OK → installatie gereed.

F

Mauvais résultat d'essai, réinstallez le raccord. Essai réussi, l'installation est terminée.

NO

Trykkprøving negativ → Re-installer kobling. Test OK → installasjon er utført.

SE

Tryckprovning falerar → Ommontera rördelen. Test OK → installation avslutad.

DK

Trykprøvning negativ → Re-installer kobling. Test OK → installationen er udført.

FIN

Paine testi hylätty → asenna uudelleen. Testi OK → asennus suoritettu.

PT

Teste de pressão falhou → Voltar a instalar o acessório → Teste OK → Instalação terminada.

ES

Test de Presion Fallo → Reinstalar el accesorio TEST OK → Instalacion completada

IT

Se test negativo → Reinstallare. Se test positivo → Installazione finita.

GR

Σε περίπτωση που η εγκατάσταση αποτύχει και υπάρχει διαρροή στη σύνδεση → Επανα-εγκαταστήσετε το σύνδεσμο. Σε περίπτωση που η δεν παρατηρηθεί διαρροή στη σύνδεση → η εγκατάσταση του συνδέσμου επί του αγωγού έχει ολοκληρωθεί με επιτυχία.

CZ

Tlaková zkouška není OK → tvarovku znovu namontovat. Tlaková zkouška OK → konec instalace.

HU

Nyomás próba sikertelen → végezze el újra az idom felhelyezését. Próba sikeres → felhelyezés befejezve.

RO

Daca testul de presiune esueaza → Se reinstaleaza fittingul. Daca rezultatul testului este OK → Instalare terminata.

PL

Nieudana próba → Ponowny montaż łącznika. Udana próba → montaż zakończony.

RUS

Опрессовка не пройдена → Установить фитинг снова. Опрессовка пройдена → Установка завершена.

# MULTI/JOINT® 3000 Plus 25"-41"



User Manual **EN**

Manuel d'instruction **F**

Manual de instalacion **ES**

Georg Fischer Waga N.V.  
Lange Veenteweg 19, 8161 PA, Netherlands  
T +31 (0) 578 678 378  
waga.ps@georgfischer.com  
www.waga.nl / www.multijoint.nl

© Georg Fischer Waga N.V.  
2023, produced in the Netherlands

## OUR WEBSITES

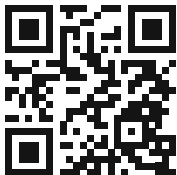

## 1

## CHECK TABLE IF CHOSEN FITTING MATCHES PIPE OD.

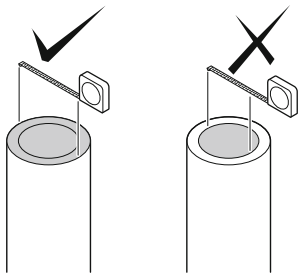

Nominal size (inch)	Range (inch)
25	24.803-26.063
27	26.181-27.441
28	27.913-29.173
30	29.331-30.591
32	31.456-32.740
33	32.952-34.212
36	35.394-36.654
37	36.969-38.228
40	39.134-40.394
41	41.024-42.283

F

Vérifiez sur le tableau si le raccord couvre bien le diamètre extérieur du tube.

ES

Ver tabla anexa para unir distintos diámetros exteriores.

2

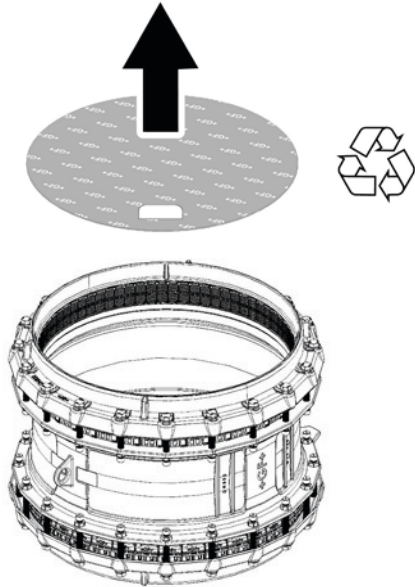
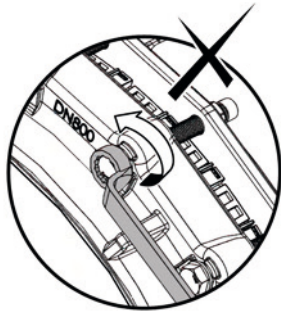

# 3

CHECK IF "FIKSERS" (METAL GRIPPERS) POSITION IS CORRECT.

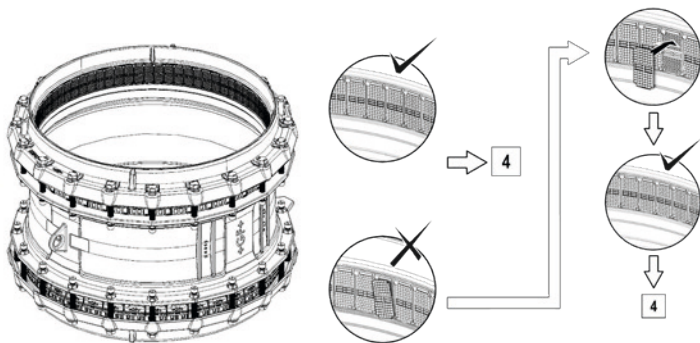

F

Assurez-vous que les "Fiksers" (les mors métalliques) sont correctement positionnés.

ES

Revise si los "Fiksers" se encuentran en la posición correcta.

# 4

**REMOVE ALL RUST, DIRT, BURRS, AND DAMAGES FROM THE PIPE.  
INSTALL ON MEDIUM CARRYING PIPE MATERIAL ONLY.**

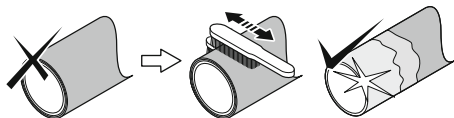
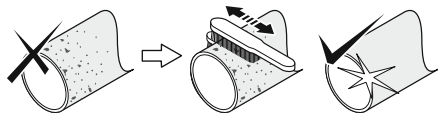

F

Éliminez la rouille, la saleté, les bourrelets de soudures et les défauts de surface du tube. Assemblez seulement sur le matériau principal du tube.

ES

Retirar toda la suciedad, polvo y daños de la tubería. Instalar solo en la tubería que transporte el agua.

## 5

## CHECK TABLE FOR MINIMUM INSERTION DEPTH (X).

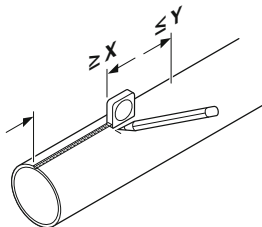

Nominal size (inch)	X Min. insertion depth (inch)*	Y Max. insertion depth (inch)*
25	8.300	12.600
27		
28		
30		
32		
33		
36	13.976	
37		
40		
41		

\* For maximum joint gap information, see our table:



F

Vérifiez sur le tableau la profondeur d'insertion (X + Y) correcte du tube.

ES

Ver tabla para la profundidad de inserción mínima (X) y máxima (Y).



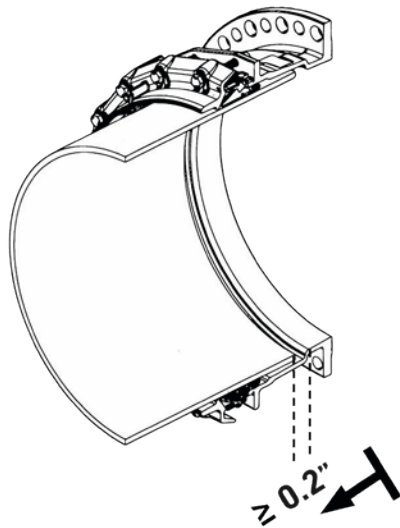
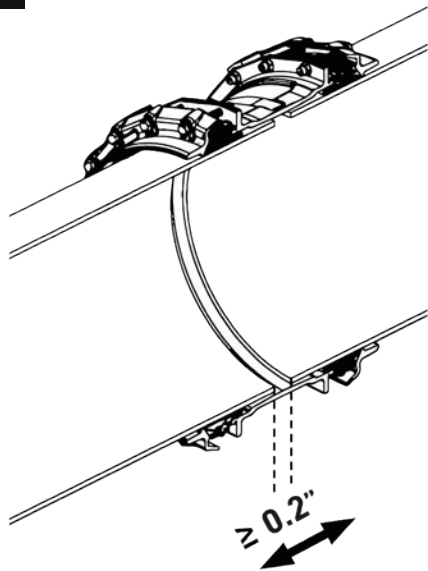

# 7

## INSERTS FOR PLASTIC PIPES. NOMINAL ANGULARITY.\*

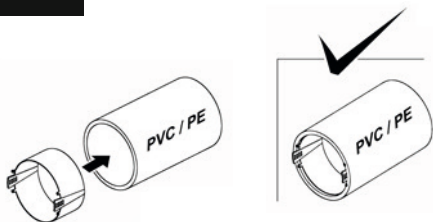

(Use insert stiffener wedge MJ 25" - 40"  
approved by Georg Fischer Waga N.V.)  
PVC C900/909 > SDR21

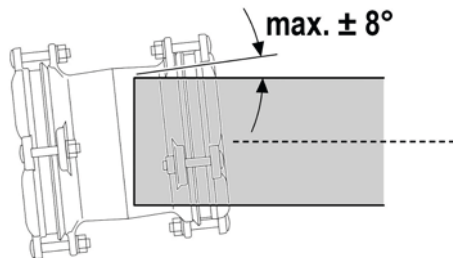
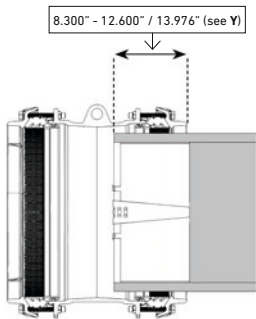

\* Based on the middle of the range.

F

\* basé sur le milieu de gamme.

ES

\* basado en el medio de rango.

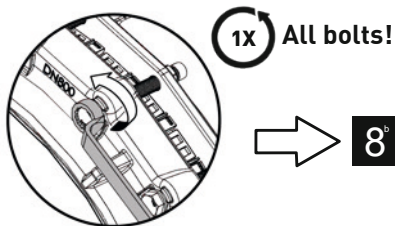
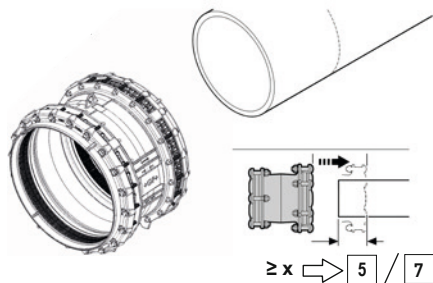
**8<sup>a</sup>****SLIDE THE MULTI/JOINT® 3000 PLUS ONTO PIPE END AND REMOVE TRANSPORT CLIP!****F**

Faites glisser le MULTI/JOINT® 3000 Plus sur l'extrémité du tuyau et retirez le clip de transport!

**ES**

Deslice el MULTI/JOINT® 3000 Plus sobre el extremo del tubo y retire el clip de transporte!

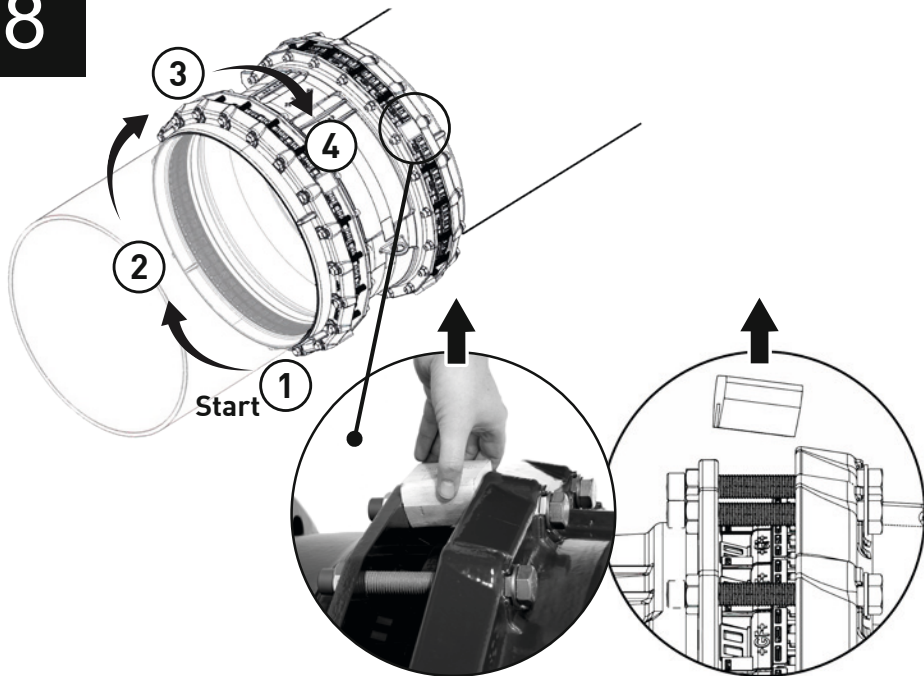
**8<sup>b</sup>****SLIDE THE MULTI/JOINT® 3000 PLUS ONTO PIPE END AND REMOVE TRANSPORT CLIP!**

9<sup>a</sup>

## TIGHTEN THE BOLTS WITH THE CORRECT TORQUE.

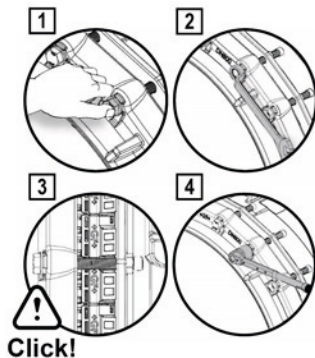
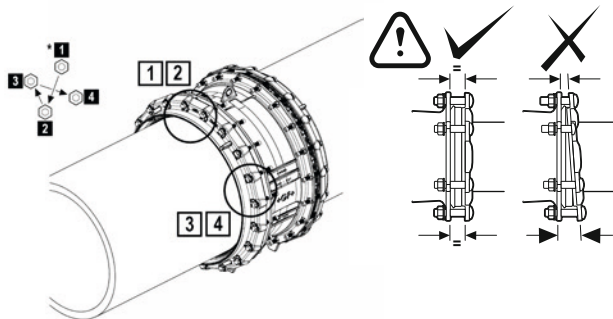

F Vérifiez dans les tableaux le couple de serrage à respecter.

ES Ver tabla para el par de apriete.

9<sup>b</sup>

## CHECK TABLE FOR INSTALLATION TORQUE AND PRESSURE RATING\*\*.

## RESTRAINT

MULTI/JOINT®  
3000 Plus  
with Fikser[S]St, DCI, GCI, AC\*, GRP\*, PVC, PE, PEX  
Consult GF for CU, PP, ABS

Nominal size (inch)	Torque (ft-lbf)		Pressure water (psi)
	Metal	Non metal	
25	150	100	150
27			
28			
30			
32			
33			
36			
37			
40			
41			

## NON RESTRAINT

MULTI/JOINT®  
3000 Plus  
without Fikser[S]St, DCI, GCI, AC, GRP, PVC, PE, PEX  
Consult GF for CU, PP, ABS

Nominal size (inch)	Torque (ft-lbf)	Pressure water (psi)
25	100	232
27		
28		
30		
32		
33		
36		
37		
40		
41		

\* NO guarantee as quality varies!

\*\* ALL FITTINGS 232 PSI RATED, SEE RESTRAINT TABLE FOR PULL OUT RESISTANT FORCES

# 10

≤ 32 °F ONLY ON PE PIPE, APPLY TORQUE (PRESCRIBED UNDER 9) ONE MORE TIME AFTER 30 MINUTES.



≤ 32 °F



30 min.



9

## PE

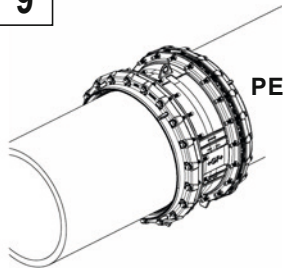

F

Répetez l'étape 9 après 30 minutes seulement sur des tubes en PE en temps glacial.

ES

≤ 32 °F Solo en la tubería de PE en condiciones de congelación aplique el par de apriete (prescrito en el punto 9) una vez más después de 30 minutos.



≤ 32 °F



11

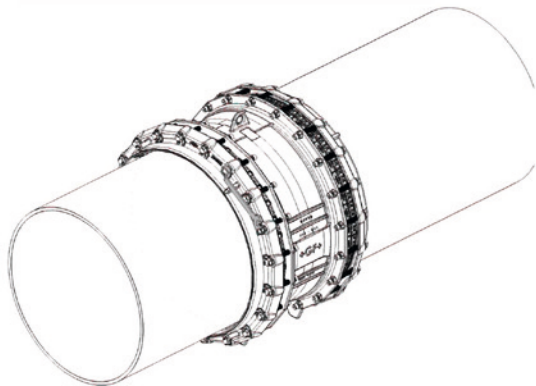
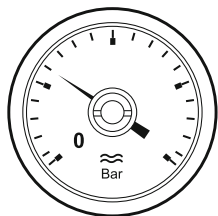

$$P_{\max} \leq 1,5 \times PFA$$

F Procédez à un essai de pression.

ES Realizar un test de presión.



# 12

**IF PRESSURE TEST FAILS: REINSTALL FITTING  
TEST OK → INSTALLATION FINISHED.**

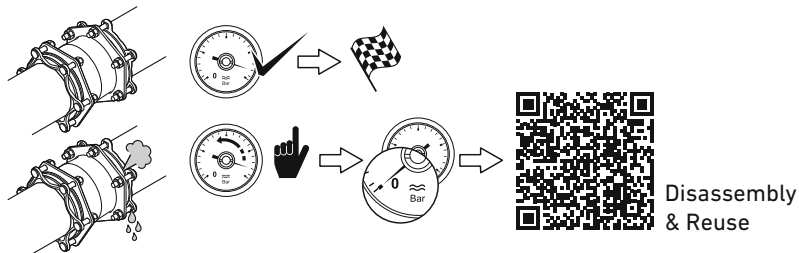

F

Mauvais résultat d'essai, réinstallez le raccord. Essai réussi, l'installation est terminée.

ES

Test de Presion Fallo → Reinstalar el accesorio TEST OK  
→ Instalacion completada.